



AIMSHOP.COM



• LAP TIMERS • LOGGERS • CAMERAS • DASHES • SENSORS • AND MORE

SHOP NOW

AiM Infotech

# Optical CAN receiver

Release 1.00

---



VISIT SUPPORT CENTER

SOFTWARE DOWNLOADS

FIRMWARE UPDATES

PRODUCT DOCUMENTATION



# 1

## Introduction

---

This receiver allows to sample lap time in the traditional way but using the CAN bus protocol. This is useful, for example, when the GPS receiver cannot be used.

The receiver part number is: **X02RXCAN0400**

# 2

## Installation and connection

---

The optical CAN receiver connects to cables labelled "CAN Exp" or to "Exp" connector of any AiM device.

Install the device so that it "sees" the transmitter placed on the track and ensure that the lap signal is not interrupted by any obstacle as shown below on the left.

We suggest to fix the CAN receiver using the two lateral thread holes shown below on the right.

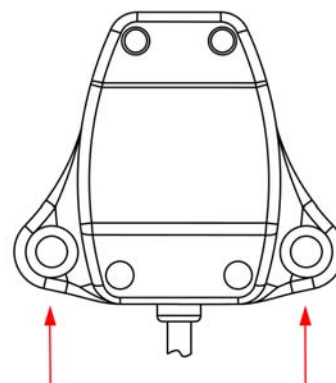

### 3

## Dimensions, pinout and technical characteristics

The drawing here below shows the receiver dimensions in millimetres [inches].

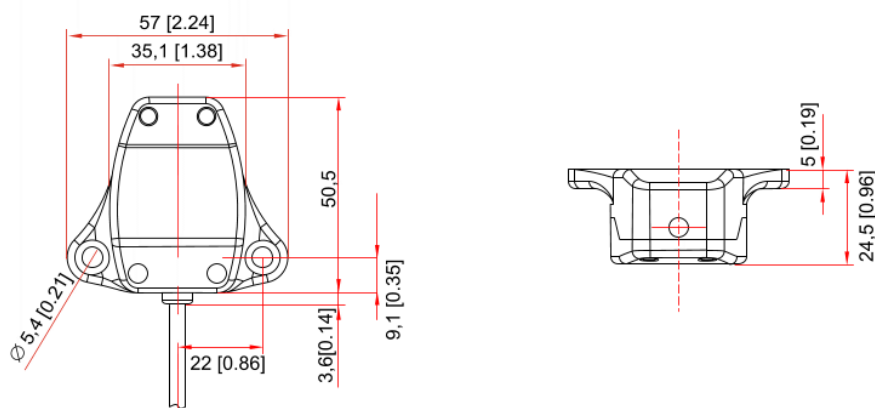

The receiver ends with a 5 pins Binder 712 male connector. The table below shows its pinout as well as the connection table.



Pin	Function
1	CAN+
2	GND
3	+Vb
4	CAN-
5	+Vbext

The receiver technical characteristics are:

- Cable length: 4m
- Dimensions: 57x54,1x54,5 mm