



AiM Infotech

Position sensor Kart steering potentiometer

Release 1.04



This datasheet explains how and where to install the rotating potentiometer, showing its electrical and mechanical characteristics too.

1

Introduction

AiM loggers can use a sensor (rotating potentiometer) to measure the displacement between two points. This potentiometer can be used to measure angular displacements such as the steering position. This is why we normally call it kart steering angle potentiometer.

2

The kit

The kart steering angle potentiometer kit includes:

- 1 kart steering potentiometer (1)
- 1 toothed belt (2)
- 1 Allen key (3)
- 2 toothed pulley (4)
- 1 bracket (5)

The kit part number is: **X05SNST01G**



2.1 Installation notes

The kart steering potentiometer can be connected to MyChron5 and MyChron5 2T **only** using MyChron Expansion analog channels and to MyChron4 and MyChron4 2T **only** using MyChron Expansion and eBox Extreme analog channels, to say:

- MyChron Expansion: channels from 1 to 4
- eBox Extreme: channels from 1 to 3

The drawing here below shows the potentiometer installed.

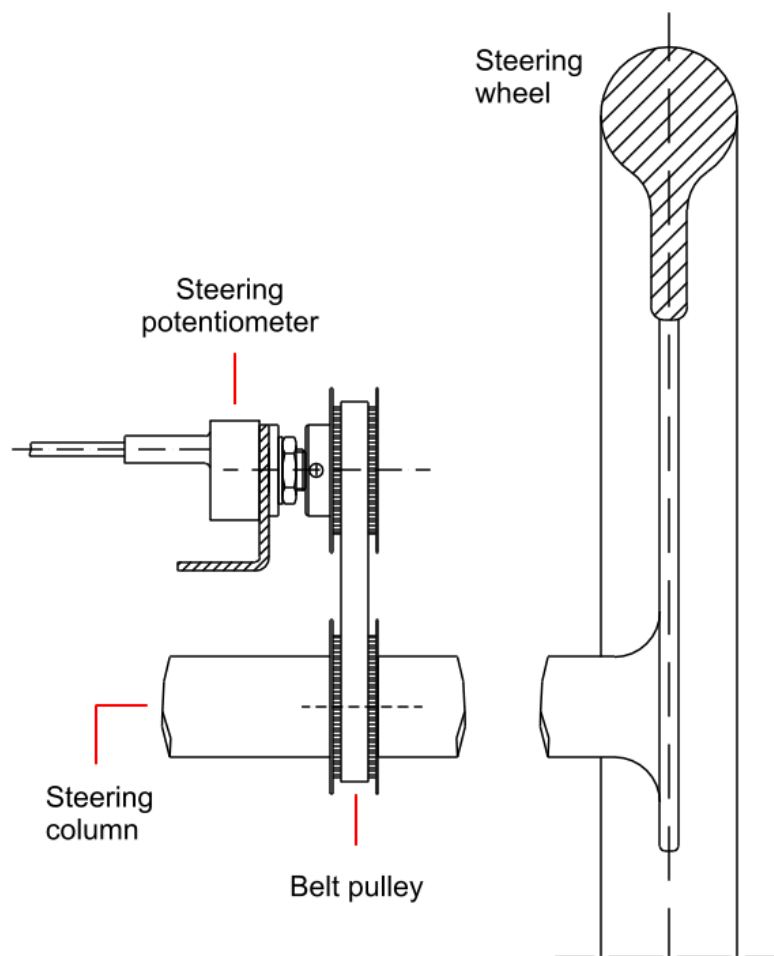

3 Dimensions, pinout and technical characteristics

The drawing here below shows the sensor dimensions in millimeters [inches].

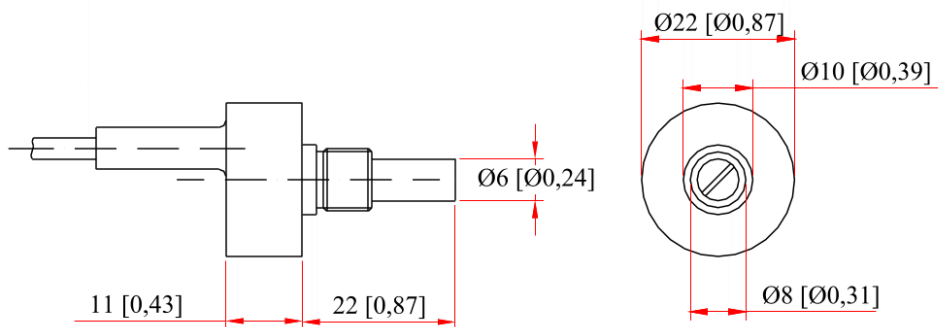

The following images shows the pulleys dimensions in millimetres [inches]:

- pulley to be installed on the potentiometer

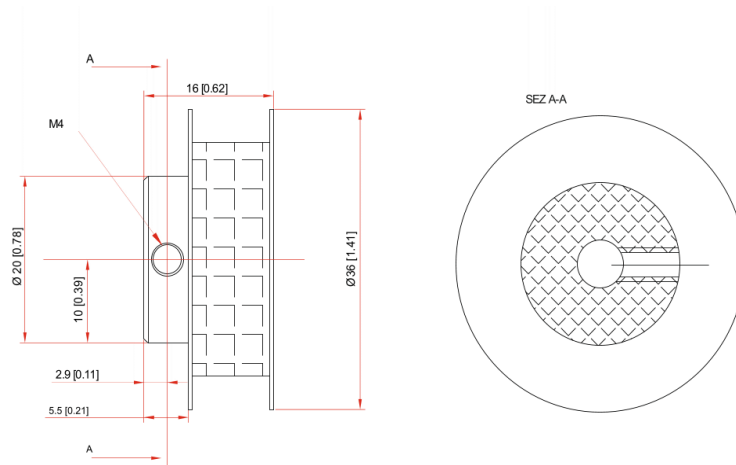

- 20 mm diameter pulley to be installed on the steering wheel for 5G potentiometer

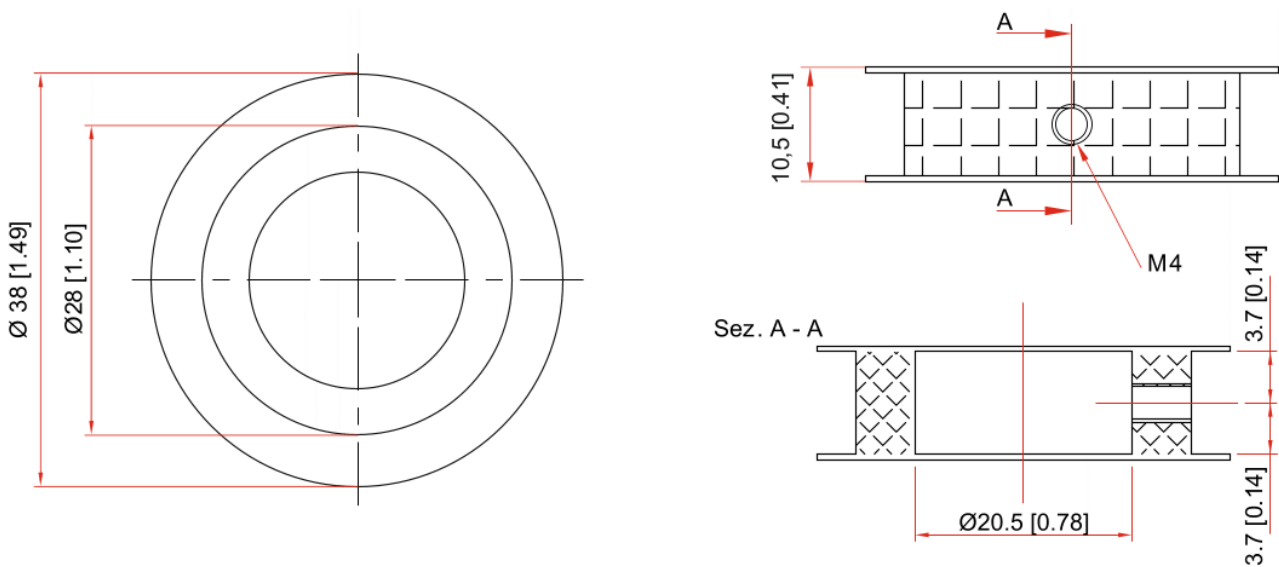

The potentiometer ends with a 4 pins Binder 719 male connector. The image here below shows the Binder connector from solder termination view and its pinout.

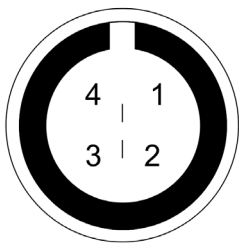

Binder connector pin	Function
1	Analog signal 0-5 V
2	GND
3	Not connected
4	V reference (4.5V)

The kart steering potentiometer **electrical characteristics** are:

- nominal resistance: 10kΩ
- tolerance on the resistance value: ±5%
- precision (%): 0.034

The kart steering potentiometer **mechanical characteristics** are:

- mechanical displacement: 1080°/5giri
- temperature working range: -55/+125 °C
- dissipated power at 40°C: 1.6W
- dissipated power at 70°C: 1W

4

Extension cables

The potentiometer is sold with a 30 cm cable and standard lengths extension cables are available as optional: 0,5 m, 1m e 1,5 m; it is also possible to ask for specific length extension cables.

Extension cables part numbers change according to their length and to the device the sensor is to be connected to.

Extension cable for connection with MyChron Expansion and eBox Extreme:

Part number:

V02PCB05BTXG – cable length: 500mm

V02PCB10BTXG – cable length: 1000mm

V02PCB15BTXG – cable length: 1500mm

V02PCB20BTXG – cable length: 2000mm

V02PCB25BTXG – cable length: 2500mm

V02PCB30BTXG – cable length: 3000mm

