



AiM Infotech

Water/oil temperature sensor M10 thermo resistor

Release 1.03



1

Introduction

AiM devices can measure and sample water/oil temperature using a sensor (thermo resistor) placed in the cooling system/oil sump.

The sensor part number is: **X05TRM10A4512BPRS**

2

Installation and connection

The thermo resistor has to be placed in the cooling system/oil sump.

We suggest to install the sensor far from heat and electromagnetic interference sources (like RPM cable or lap receiver cables).

With reference to the images here below, to install the sensor use the optional M10 thread inline water fitting (part number **LAA54120R**) shown on the left:

- cut the water pipe
- connect the inline water fitting to the pipe fixing two metal wraps in the points highlighted in the draw below
- screw the thermo resistor in the hole as shown on the right.

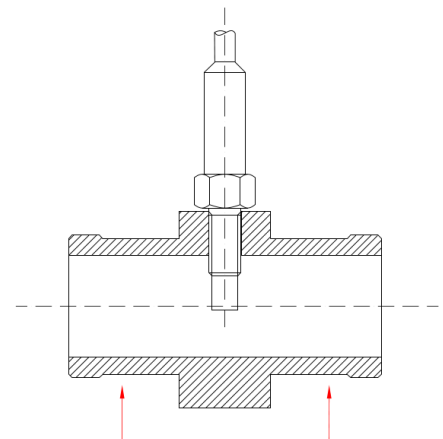

3 Dimensions, pinout and technical characteristics

The draws here below show the sensor dimensions on the left and the inline water fitting dimensions on the right in millimetres [inches].

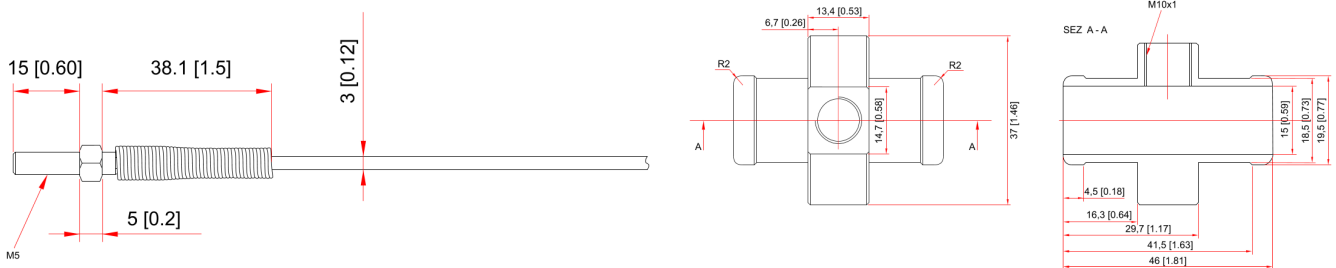

The sensor ends with a 4 pins male 719 Binder connectors that features a 2kΩ 1% resistor between pins 1 and 4. Here below you see the connector pinout solder termination view as well as the connection table.

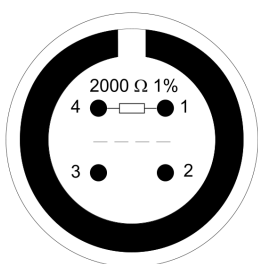

Pin	Function
1	Analog signal
2	GND
3	Not connected
4	+Vreference

The sensor technical characteristics are:

- Temperature working range: 0/150°C
- cable sensor length: 250 mm

4

Extension cables

The sensor is sold with a 25 cm cable and standard lengths extension cables are available as optional; it is also possible to ask for specific length extension cables.

Extension cables part numbers change according to their length and to the device the sensor is to be connected to.

Mandatory extension cable for connection with:

- EVO4
- EVO4S
- Channel Expansion
- MyChron5 – MyChron5 2T
- MyChron Expansion

Part numbers:

V02PCB05BTXG – cable length: 500 mm

V02PCB10BTXG – cable length: 1000 mm

V02PCB15BTXG – cable length: 1500 mm

V02PCB20BTXG – cable length: 2000 mm

V02PCB25BTXG – cable length: 2500 mm

V02PCB30BTXG – cable length: 3000 mm

Extension cable for connection with:

- MXG
- MXS
- MXL2
- MXS Strada
- EVO5
- MXL Strada/Pista/Pro05

Part numbers:

V02PCB05B – cable length: 500mm

V02PCB10B – cable length: 1000mm

V02PCB15B – cable length: 1500mm

V02PCB20B – cable length: 2000mm

V02PCB25B – cable length: 2500mm

V02PCB30B – cable length: 3000mm

